

SECURE LAPTOP CABINETS

Digital Education Revolution: Keeping your investments safe

- Flexible security options
- 2 available sizes
- Available in a range of appealing colours
- Fully welded frame with recessed doors and side panels



Server
Racks
Australia

T: (02) 6298 1855
www.server-racks-australia.com.au



PROUDLY AUSTRALIAN
DESIGNED | OWNED | MANUFACTURED

Date: October 15, 2010

www.act.crimestoppers.com.au

On Monday (11 October) police responded to a report of a burglary at Telopea Park School in Barton. Police were informed by a school staff member that 96 mini laptop computers had been stolen from within the school sometime between Friday afternoon (8 October) and Monday morning (11 October).

Don't let this happen to you!

Schools have become a prime target for criminals with the introduction of 141,000 laptops by the federal government. The best way to ensure that your schools investment remains secure is with the use of an SRA secure laptop cabinet.

SRA have been involved in some of the highest security IT installations in Australia.

- The laptop cabinets come in three security levels - standard, high and advanced with flexible lock and key solutions available.
- The cabinet can be bolted to the floor for assurance that the entire cabinet isn't stolen.
- Comes in a range of appealing colours to keep classrooms colourful and stimulating.
- Comes in two sizes with 12 or 24 shelves holding anywhere from 24 to 48 laptops depending on models
- Staged Power-On ensures reliable startup after a power outage.
- Laptops are stored horizontally to ensure no damage is done to external clips and fragile features on the laptop.
- Customisable overall external dimensions can be supplied to suit special requirements

Standard Dulux Colours



Yellow Gold
#98433617



Graphite Sorouk
#93551677



Lime Satin
#96160435



Classic Pearl White
#27281880



Mannex Black (Black Texture)
#90132679



Mannex Suade (Grey Nurse Texture)
#90137543

SECURITY LEVEL

STANDARD

For use in situations where usage needs to be controlled while the laptops are stored in a room that already has adequate security.



HIGH

Provides the most flexible lock and keying options. The padlock or lock can be selected to suit the existing key management systems already used in the organisation.



ADVANCED

The highest security with the use of a government secure SCEC Endorsed Class C or 8-digit electronic lock. Includes anti-drill plate and an independent locking and handle mechanisms.



FEATURES

- Folding cable management arms
- Cabinet serial numbers for key management
- Smooth sliding shelves - Can hold 2x netbooks per shelf
- Knock out cable entry holes
- Power distribution units (power boards) mounted in the back of the cabinet
- Unique rear cable management and power supply storage tray
- Castors can be fitted in case the cabinets need to be moved from room to room
- 19" Rack units at the top of the cabinet

- Cable managers keep power cables from hanging freely and prevents damage to the insulation

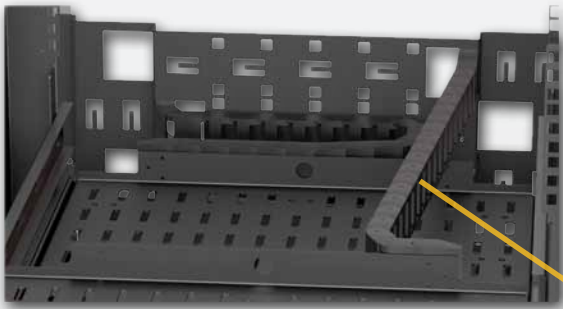

- Matching tags are attached to each key set for quick and easy key management



- Fully extendable shelves to allow full access to equipment



- Castors with/without brakes by request



Front view

TOP SECTION VIEW showing two netbooks per shelf.
Cable manager extends with the shelf to keep cables safe

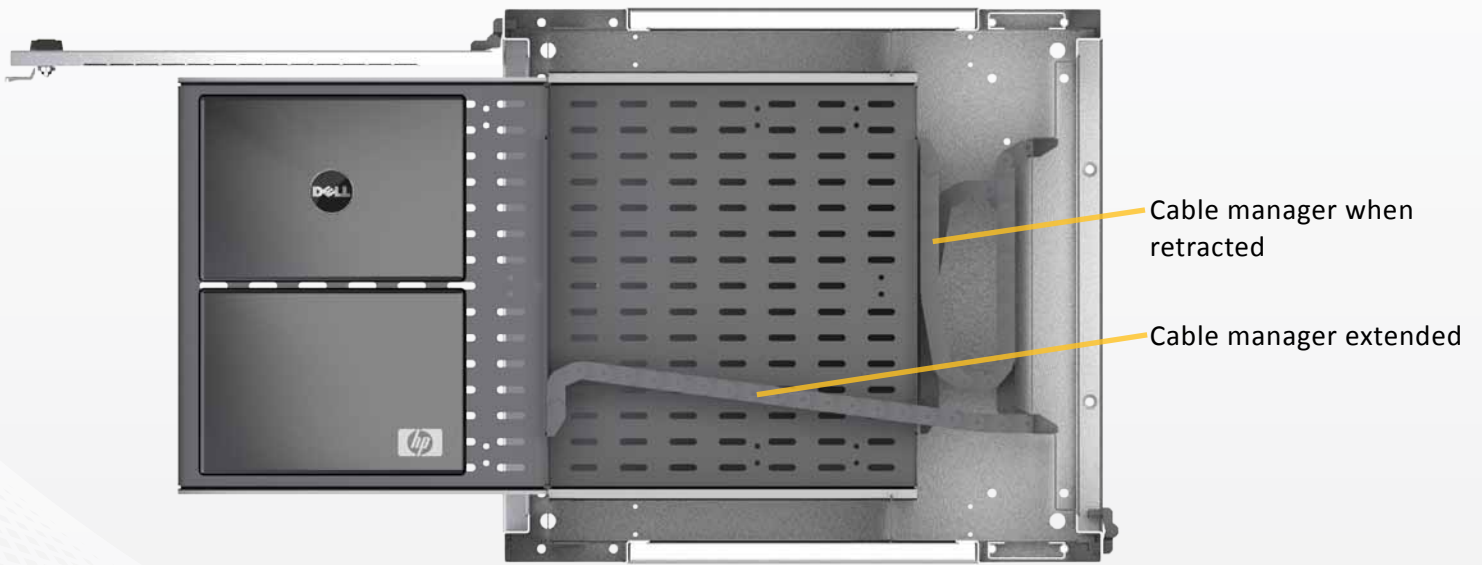

● 19" Rack mounting space for switches or routers

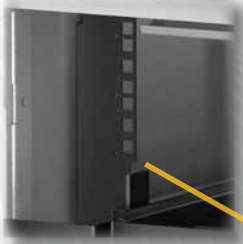

● Cable entry knockouts to allow for additional cable access if required.



● 4x power boards with 6 outlets for recharging laptops.



● Perforated cable tray allows for easy cable management and storage of laptop PSU's



Rear view

SPECIFICATIONS

| Model | Small | Large |
|-----------------------------------|--|-------------------------------------|
| Height | 1050mm | 1750mm |
| Width | 600mm | 600mm |
| Depth | 650mm | 650mm |
| Storage Capability | 12 Shelves - 12 laptops/24 Netbooks | 24 Shelves - 24 laptops/48 Netbooks |
| (A x B x C usable area per shelf) | 400 x 436 x 50 | 400 x 436 x 50 |
| Rack Mounting Space | 3RU | 3RU |
| Cooling Options | Optional 5 Fan Thermostatic Airflow Module (300cfm) Uses 1x Australian GPO | |
| Power Outlets | 24x Australian GPO | 48x Australian GPO |
| Frame Construction | 2mm Zinc Anneal Steel to resist corrosion - Fully Welded | |
| Anchoring System | 4x Fixing points only accessible from inside the cabinet | |
| Cable Management | Industrial Quality Cable Managers to ensure no abrading of power cords | |

| Part Numbers | Small (1050x600x650) | Large (1750x600x650) |
|-------------------------|----------------------|----------------------|
| Security Level | | |
| Standard | 800-390079 | 800-390080 |
| High - Padlocked Handle | 800-390083 | 800-390084 |
| High - Integrated Key | 800-390081 | 800-390082 |
| Advanced - Class C | 800-390085 | 800-390086 |
| Advanced - Digital | 800-390087 | 800-390088 |

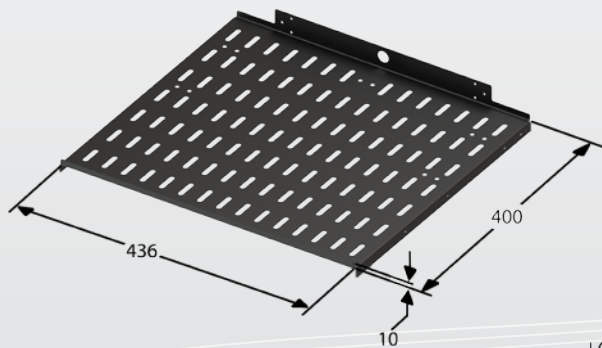

The ventilated shelves are spaced 50mm apart and have a depth of 400mm

